

**SCHEDA INSTALLAZIONE | INSTALLATION SHEET**

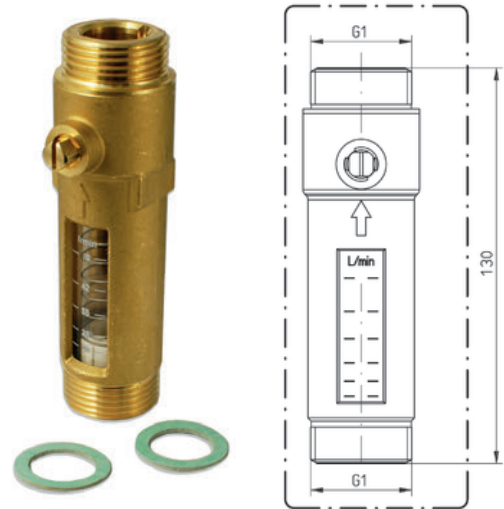
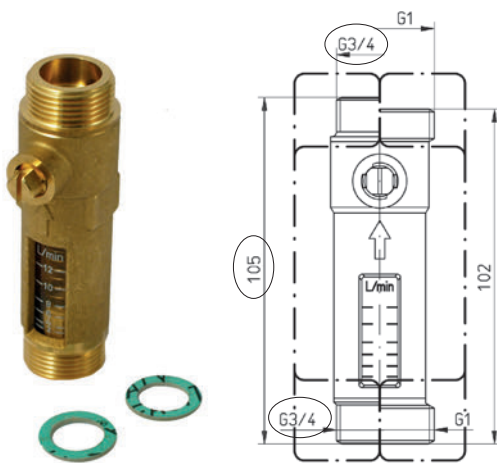

Range (l/min)	Ø - Kv	Cod.
2-12	Ø ¾" - Kv 3.0	7045554

Range (l/min)	Ø - Kv	Cod.
5-42	Ø 1" - Kv 9.7	7045558
20-70	Ø 1" - Kv 12.9	7045559

**DESCRIZIONE**

Le valvole di bilanciamento sono dispositivi idraulici che consentono di regolare la portata del fluido verso i terminali dell'impianto. Rispettare la direzione del flusso come indicato dalla freccia impressa sul corpo. La valvola può essere installata orizzontale o verticale con qualsiasi senso di flusso. Per una precisa e stabile lettura assicurare un tratto rettilineo di almeno 5 diametri prima del dispositivo.

**DESCRIPTION**

The balancing valves are hydraulic devices that allow to adjust the flow of the fluid towards the outlets of the installation. Please pay attention to the direction of the flow as indicated by the arrow printed on the body. The valve can be mounted in horizontal or vertical position with any sense of flow. For an accurate and stable reading please provide a straight pipe with an overall length of at least 5 times the diameter of the pipe.

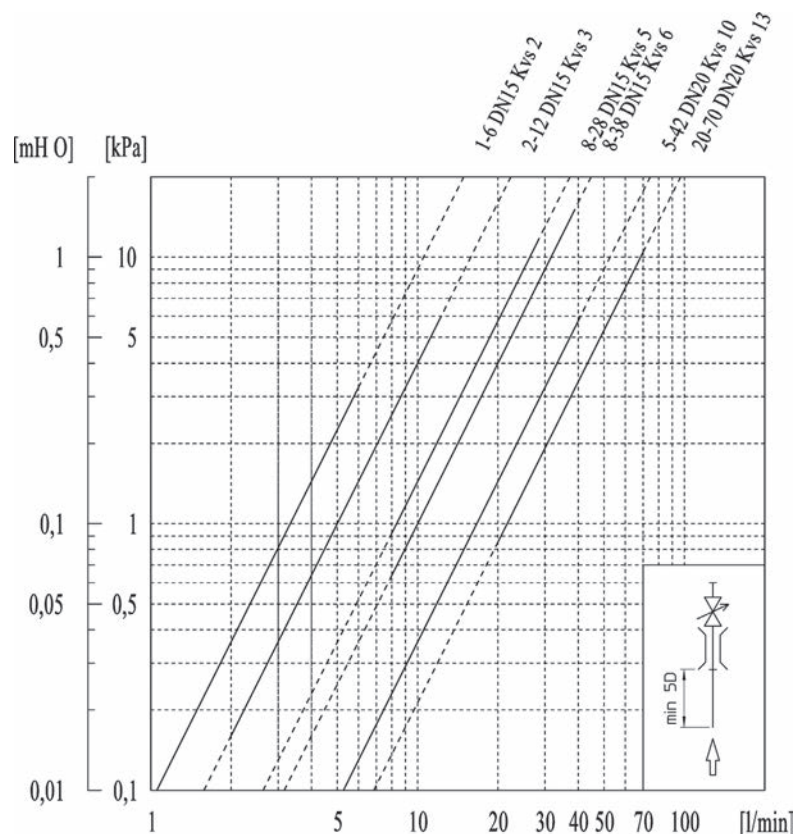
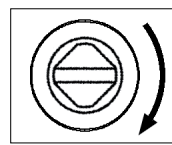
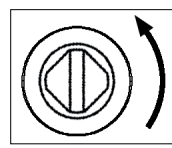
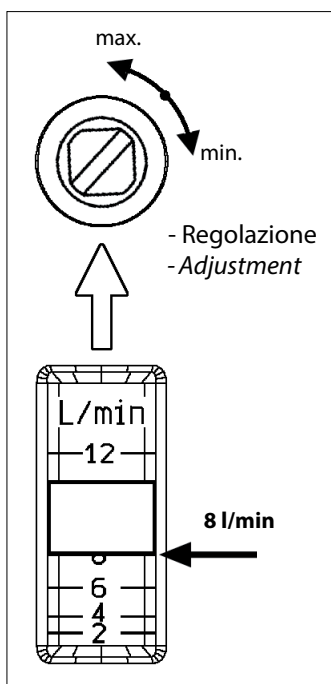

La lettura della portata viene fatta in corrispondenza della parte bassa dell'indicatore mobile.

The reading of the flow is done at the lower part of the mobile indicator.

## SCHEDA INSTALLAZIONE | INSTALLATION SHEET

### SMALTIMENTO



Non disperdere nell'ambiente. Per lo smaltimento degli imballaggi e dei prodotti a fine vita, fare sempre riferimento alle leggi locali che recepiscono le Direttive 2018/851/UE e 2018/852/UE. In Italia riferirsi ai D.Lgs 152/2006 "Testo Unico in materia Ambientale" (T.U.A.) Art. 219, comma 5 riformato dal D.Lgs 116/2020. Verificare con le autorità locali le modalità di raccolta differenziata in vigore attenendosi alle normative vigenti. Tramite il QR-Code del prodotto è possibile visualizzare la guida sulla etichettatura per la corretta gestione dei rifiuti.

### DISPOSAL



*Do not dispose of in the environment. For the disposal of packaging and end-of-life products, always refer to the local laws implementing Directives 2018/851/EU and 2018/852/EU. In Italy refer to D.Lgs 152/2006 "Testo Unico in materia Ambientale" (T.U.A.) Art. 219, comma 5 reformed by D.Lgs 116/2020. Check with the local authorities on the waste collection methods in force by following the regulations in force. Via the QR-Code of the product you can view the labelling guide for correct waste management.*

